

General description

Symbol	Value
V_{DSS} @ $T_C=25^\circ\text{C}$	Min 650V
I_D @ $T_C=25^\circ\text{C}$	7.0A
$R_{DS(on)}$	Max 1.4Ω
Q_G	Typ 21nC

Features

- Gate Charge(Typ. $Q_G=21\text{nC}$)
- High Voltage (Min. $V_{DSS}=650\text{V}$)
- 100% Avalanche Tested

Package

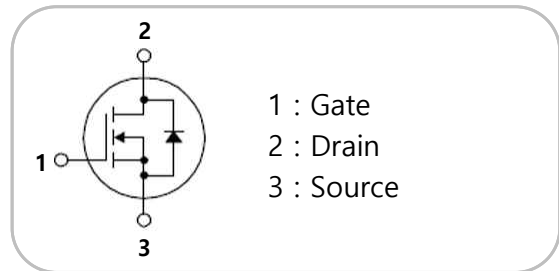
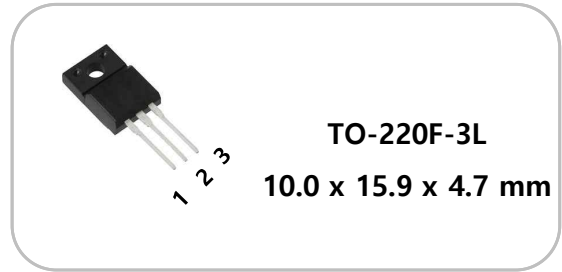

Maximum Ratings ($T_C = 25^\circ\text{C}$)

Parameter	Symbol	Test Condition	Value	Units
Drain-source voltage	V_{DSS}	$V_{GS}=0\text{V}$, $I_D=250\mu\text{A}$	650	V
Drain current (DC)	I_D	$T_C=25^\circ\text{C}$	7.0	A
		$T_C=100^\circ\text{C}$	3.4	A
Drain current (Pulsed)	I_{DM}	Pulse width limited by junction temperature	28.0	A
Gate-source voltage	V_{GS}	-	±30	V
Single pulsed avalanche energy	E_{AS}	$I_{AS}=7.0\text{A}$, $R_G=25\Omega$, $V_{DD}=50\text{V}$, $L=7.6\text{mH}$	201	mJ
Power dissipation	P_D	$T_C=25^\circ\text{C}$	40	W
Operating junction	T_j	-	-55 to 150	$^\circ\text{C}$
Storage temperature	T_{stg}	-	-55 to 150	$^\circ\text{C}$



Electrical Characteristics ($T_j = 25^\circ\text{C}$)

Parameter	Symbol	Test Condition				Units
			Min	Typ	Max	
Drain-source breakdown voltage	$V_{(BR)DSS}$	$V_{GS}=0V, I_D=250\mu A$	650	-	-	V
Zero gate voltage drain current	I_{DSS}	$V_{DS}=650V, V_{GS}=0V$	-	-	1.0	μA
Gate-source leakage current	I_{GSS}	$V_{GS}=\pm 30V, V_{DS}=0V$	-	-	± 100	nA
Gate threshold voltage	$V_{GS(th)}$	$V_{DS}=V_{GS}, I_D=250\mu A$	2.0	-	4.0	V
Drain-source on-state resistance	$R_{DS(on)}$	$V_{GS}=10V, I_D=3.5A$	-	1.2	1.4	Ω
Input capacitance	C_{iss}	$V_{DS}=25V, V_{GS}=0V, f=1MHz$	-	1006	1258	pF
Output capacitance	C_{oss}		-	98	123	
Reverse transfer capacitance	C_{rss}		-	10	15	
Total gate charge	Q_G	$V_{DS}=520V, V_{GS}=10V, I_D=7A$	-	21	27	nC
Gate-source charge	Q_{GS}		-	6	-	
Gate-drain charge	Q_{GD}		-	5	-	
Turn on delay time	$t_{d(on)}$	$V_{DD}=300V, I_D=7A, R_G=25\Omega$	-	18	-	ns
Rise time	t_r		-	19	-	
Turn off delay time	$t_{d(off)}$		-	72	-	
Fall time	t_f		-	28	-	



Body Diode(Source – Drain) Electrical Characteristics (T_j = 25°C)

Parameter	Symbol	Test Condition	Value			Units
			Min	Typ	Max	
Continuous diode forward current	I _S	-	-	-	7.0	A
Maximum pulsed drain to source diode forward current	I _{SM}	-	-	-	28.0	A
Forward voltage	V _{SD}	I _{SD} =7A, V _{GS} =0V	-	-	1.4	V
Reverse recovery time	t _{rr}	I _{SD} =7A, V _{GS} =0V di/dt=100A/μs	-	365.0	-	ns
Reverse recovery charge	Q _{rr}		-	3.4	-	uC



Thermal Characteristics(T_C = 25°C)

Symbol	Parameter	Typ	Max	Units
R _{th(j-c)}	Junction to case	-	3.12	°C/W

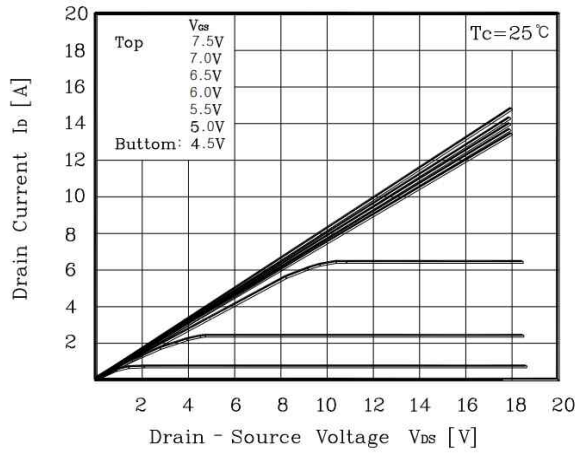

Typical Electrical Characteristics Curves (T_j = 25°C)

V_{DS} – I_D Characteristics



V_{GS} – I_D Characteristics

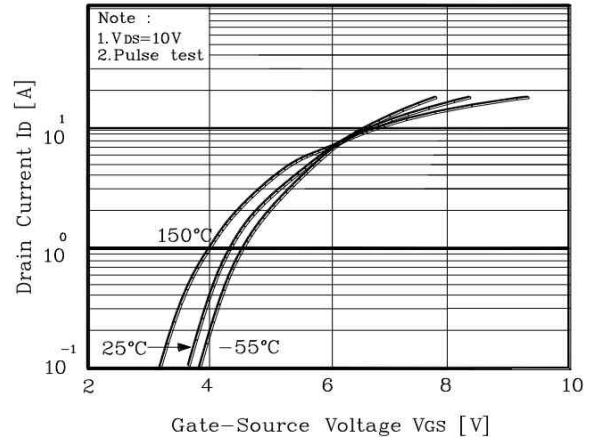

I_D – R_{DS(on)} Characteristics

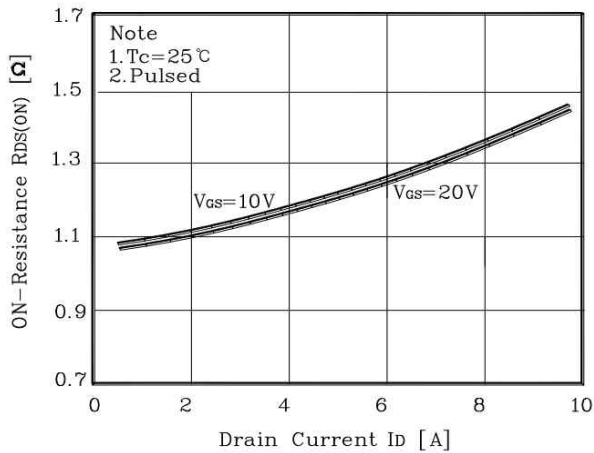

V_{SD} – I_S Characteristics

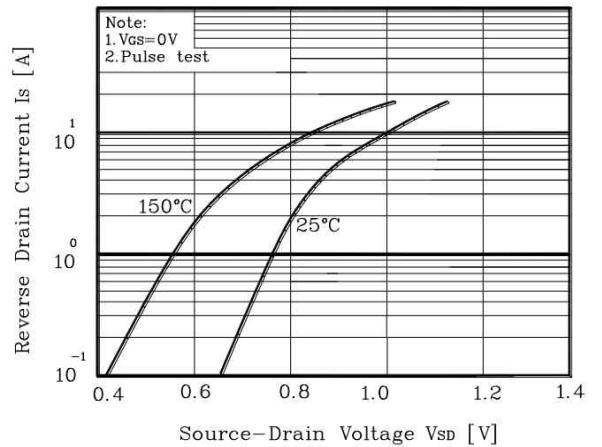

V_{DS} – C_T Characteristics

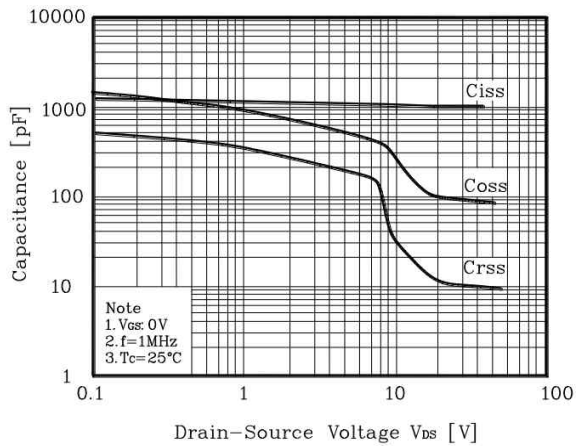

Q_g – V_{GS} Characteristics

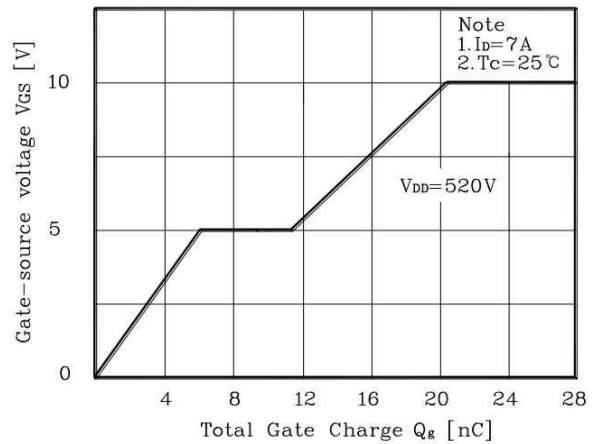

Typical Electrical Characteristics Curves ($T_j = 25^\circ\text{C}$)

$T_j - V_{DSS}(\text{Normalized})$ Characteristics

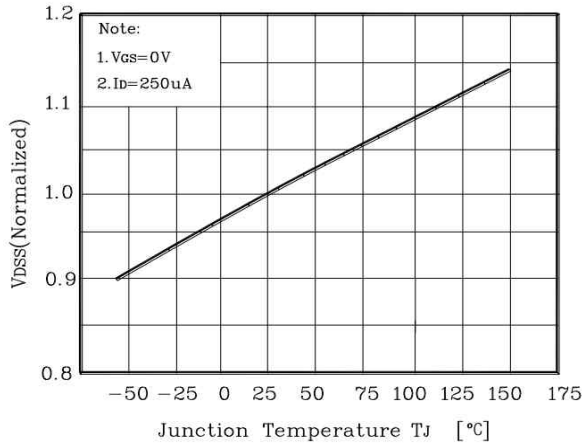

$T_j - R_{DS(on)}(\text{Normalized})$ Characteristics

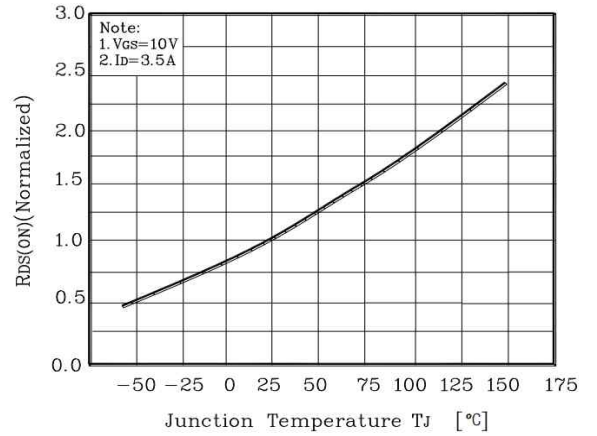

$T_c - I_D$ Characteristics

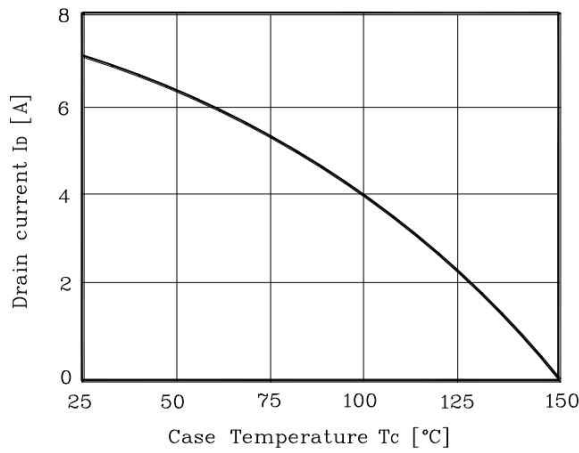

SOA Characteristics

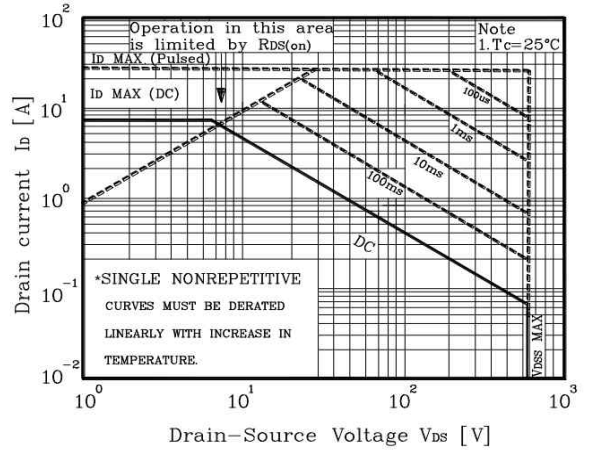

Package Dimensions(TO-220F-3L)

[Unit : mm]

SYMBOL	MIN	MAX
A	4.50	4.90
A1	2.34	2.74
A2	2.56	2.96
b	0.70	0.90
b1	1.27	1.47
c	0.45	0.60
D	15.67	16.07
E	9.96	10.36
e	2.54 BSC	
H	6.48	6.88
L	12.68	13.28
L1	3.03	3.43
φP	3.08	3.28
Q	3.20	3.40

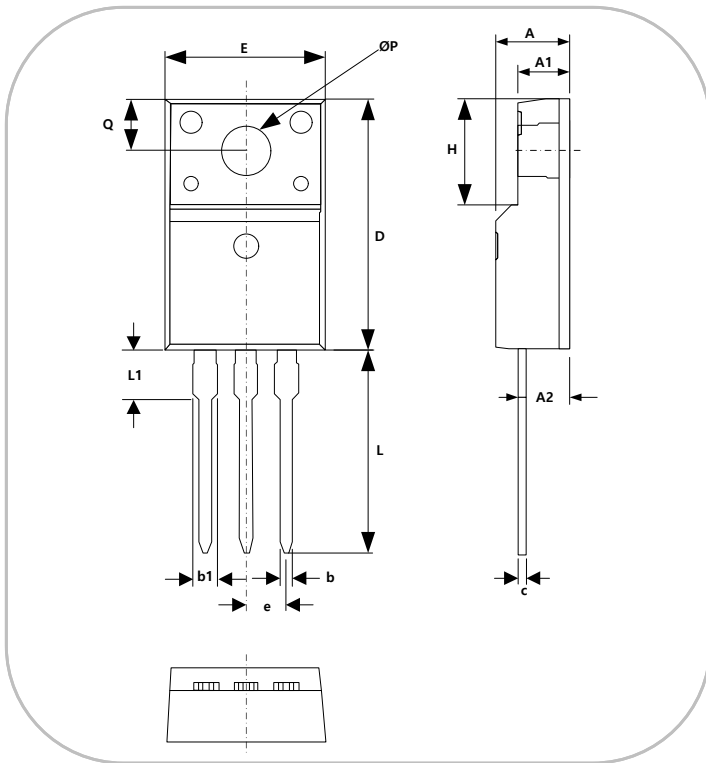

Marking Information

