

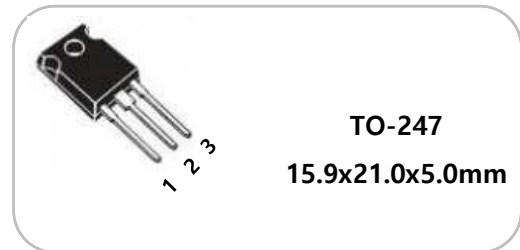

General description

Symbol	Value
V_{DSS} @ $T_C=25^\circ\text{C}$	Min 650V
I_D @ $T_C=25^\circ\text{C}$	70A
$R_{DS(on)}$	Max 41mΩ
Q_G	Typ 180nC

Package

Features

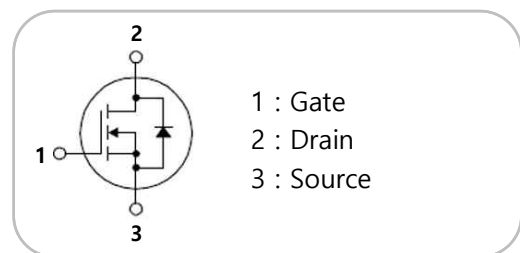
- Gate Charge(Typ. $Q_g=180\text{nC}$)
- Improved dv/dt Capability
- 100% Avalanche Tested



Applications

- LCD/LED/PDP TV
- Telecom/Server Power supplies
- AC-DC Power Supply
- Solar inverters

Maximum Ratings ($T_C = 25^\circ\text{C}$)

Parameter	Symbol	Test Condition	Value	Units
Drain - source voltage	V_{DSS}	$V_{GS}=0\text{V}$, $I_D=1\text{mA}$	650	V
Drain current	I_D	$T_C=25^\circ\text{C}$	70	A
Drain current	I_{DM}	Pulse width limited by junction temperature	230	A
Gate-source voltage	V_{GS}	-	± 20	V
Single pulsed avalanche energy	E_{AS}	$I_{AS}=15.0\text{A}$, $R_G=25\Omega$, $V_{DD}=100\text{V}$, $L=20\text{mH}$	4469	mJ
Power dissipation	P_D	$T_C=25^\circ\text{C}$	500	W
Operating junction	T_j	-	-55 to 150	$^\circ\text{C}$
Storage temperature	T_{stg}	-	-55 to 150	$^\circ\text{C}$



Electrical Characteristics ($T_j = 25^\circ\text{C}$)

Parameter	Symbol	Test Condition	Value			Units
			Min	Typ	Max	
Drain-source breakdown voltage	$V_{(BR)DSS}$	$V_{GS}=0V, I_D=250\mu A$	650	-	-	V
Zero gate voltage drain current	I_{DSS}	$V_{DS}=650V, V_{GS}=0V$	-	-	20	μA
Gate-source leakage current	I_{GSS}	$V_{GS}=\pm 20V, V_{DS}=0V$	-	-	± 100	nA
Gate threshold voltage	$V_{GS(th)}$	$V_{DS}=V_{GS}, I_D=1mA$	4	-	5	V
Drain-source on-state resistance	$R_{DS(on)}$	$V_{GS}=10V, I_D=38A$	-	38	41	mΩ
Gate input resistance	R_G	$V_{GS}=0V, f=1MHz$	-	3	4	Ω
Input capacitance	C_{iss}	$V_{DS}=100V, V_{GS}=0V$ $f=1MHz$	-	7500	-	pF
Output capacitance	C_{oss}		-	220	-	
Reverse transfer capacitance	C_{rss}		-	30	-	
Total gate charge at 10V	$Q_{G(tot)}$	$V_{DS}=380V, I_D=38A,$ $V_{GS(on)}=10V, V_{GS(off)}=0V$	-	180	-	nC
Gate-source charge	Q_{GS}		-	40	-	
Gate-drain charge	Q_{GD}		-	80	-	
Turn on delay time	$t_{d(on)}$	$V_{DS}=380V, I_D=38A,$ $V_{GS}=10V, R_G=4.7\Omega$	-	55	-	ns
Rise time	t_r		-	65	-	
Turn off delay time	$t_{d(off)}$		-	175	-	
Fall time	t_f		-	48	-	



Body Diode(Source – Drain) Electrical Characteristics (T_j = 25°C)

Parameter	Symbol	Test Condition	Value			Units
			Min	Typ	Max	
Continuous diode forward current	I _S	-	-	-	70.0	A
Maximum pulsed drain to source diode forward current	I _{SM}	-	-	-	230.0	A
Forward voltage	V _{SD}	I _{SD} =50A, V _{GS} =0V	-	-	1.25	V
Reverse recovery time	t _{rr}	I _{SD} =26A, V _{GS} =0V di/dt=100A/μs	-	207	-	ns
Reverse recovery charge	Q _{rr}		-	1.5	-	nC

Thermal Characteristics(T_C = 25°C)

Symbol	Parameter	Typ	Max	Units
R _{th(j-c)}	Sensing current=1mA, Heating Current=30A	0.25	-	°C/W

t_p – Z_{th(j-c)} Characteristics

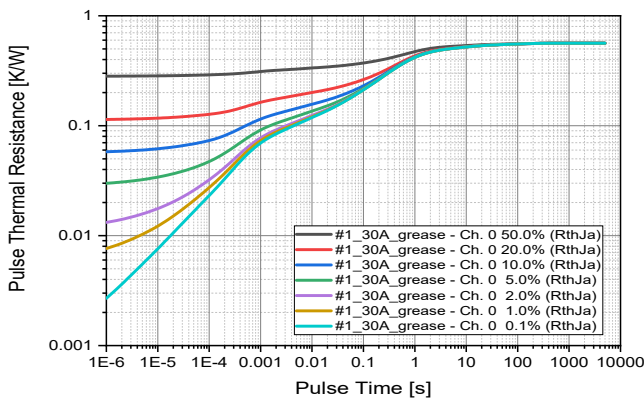

Typical Electrical Characteristics Curves ($T_j = 25^\circ\text{C}$)

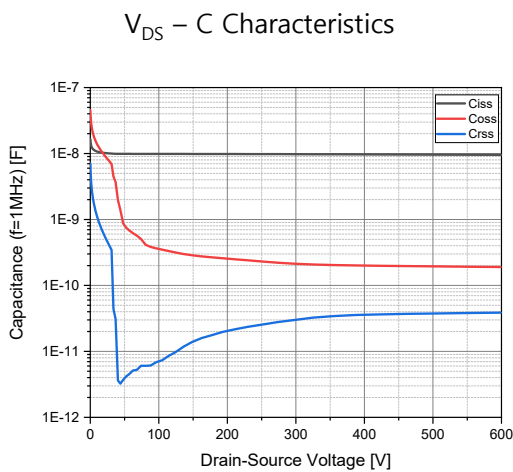
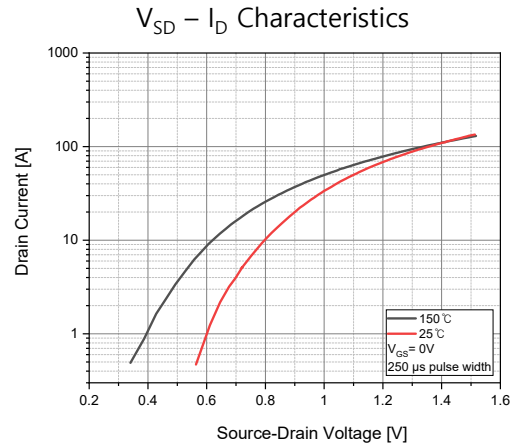
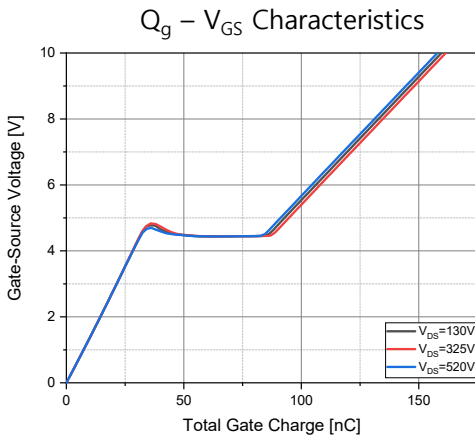
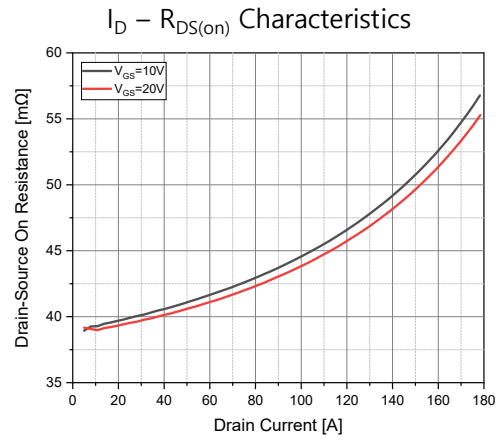
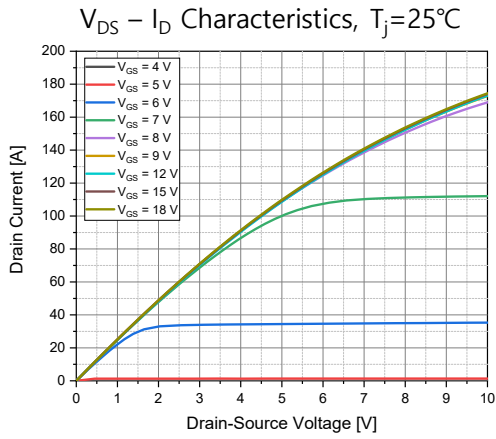

Typical Electrical Characteristics Curves (T_j = 25°C)

V_{GS} – I_D Characteristics, T_j=25°C

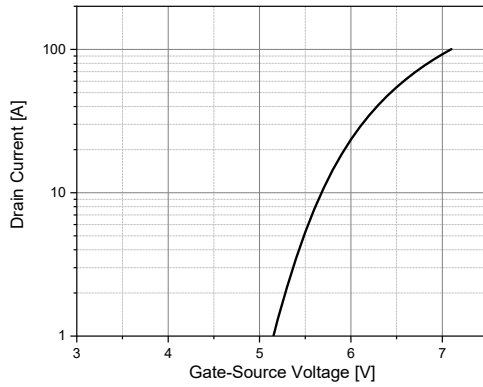

V_{GS} – R_{DS(on)} Characteristics

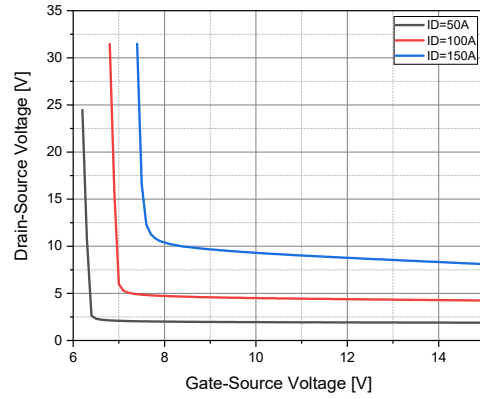

V_{GS} – V_{DS} Characteristics

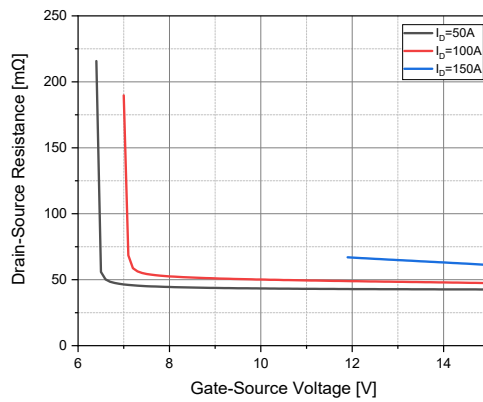

Package Dimensions(TO-247)

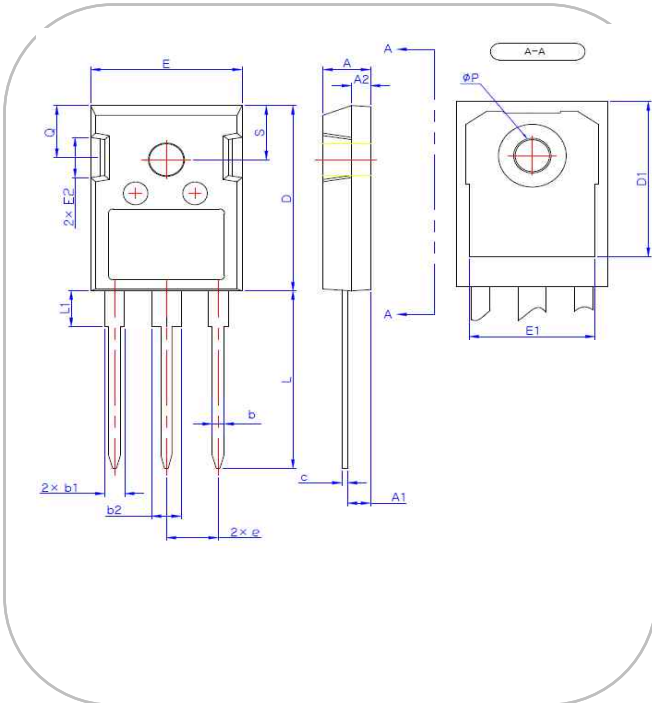

SYMBOL	MIN	NOM	MAX
A	4.80	5.00	5.20
A1	2.29	2.36	2.54
A2	1.90	2.00	2.10
b	1.10	1.20	1.30
b1	1.91	2.11	2.20
b2	2.92	3.10	3.20
c	0.50	0.60	0.70
D	20.80	21.07	21.34
D1	17.43	17.63	17.83
E	15.75	15.94	16.13
E1	13.06	13.26	13.46
E2	4.32	4.58	4.83
e	5.45 BSC		
L	19.85	20.00	20.25
L1	-	-	4.49
ΦP	3.55	3.60	3.65
Q	5.59	5.89	6.19
S	6.15 BSC		

Marking Information

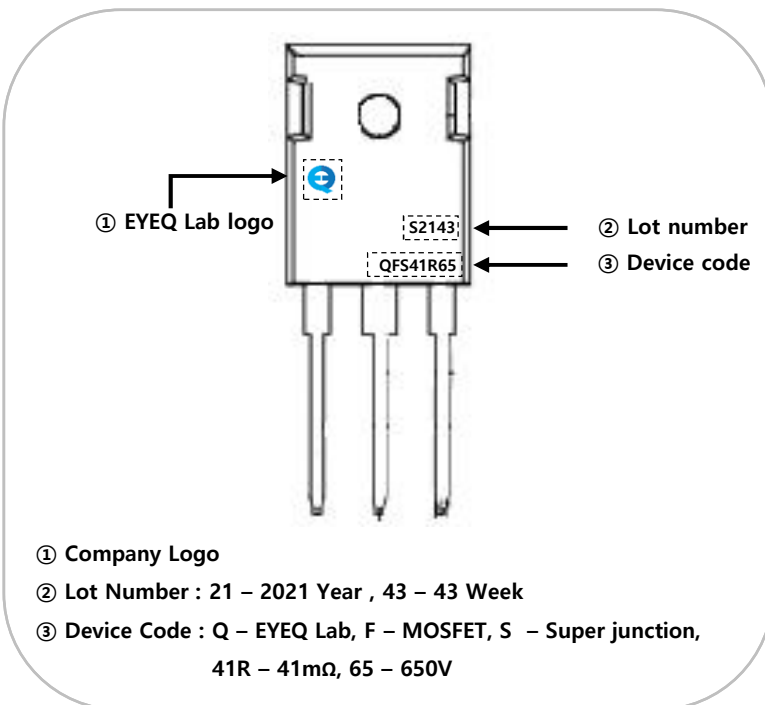

- ① Company Logo
- ② Lot Number : 21 – 2021 Year , 43 – 43 Week
- ③ Device Code : Q – EYEQ Lab, F – MOSFET, S – Super junction, 41R – 41mΩ, 65 – 650V

